

A Sealed, Light-weight gRPC-Based Muon Telescope for Muography Applications

**D. Ahmadi¹, M. Tytgat¹, S. Ikram², A. Giammanco², E. Cortina Gil², P. Demin²,
A. Biolchini², G. Nyitrai², H. Basiri², R. Karnam³, V. K. S. Kashyap^{3,4}, B. Mohanty^{3,4}**

1. Inter-University Institute for High Energies (IIHE), Vrije Universiteit Brussel, Brussels, Belgium

2. Centre for Cosmology, Particle Physics and Phenomenology, UCLouvain, Louvain-la-Neuve, Belgium

3. Centre for Medical and Radiation Physics, National Institute of Science Education and Research Bhubaneswar, Jatni, Khurda 752050, Odisha, India

4. School of Physical Sciences, National Institute of Science Education and Research Bhubaneswar, Jatni, Khurda 752050, Odisha, India

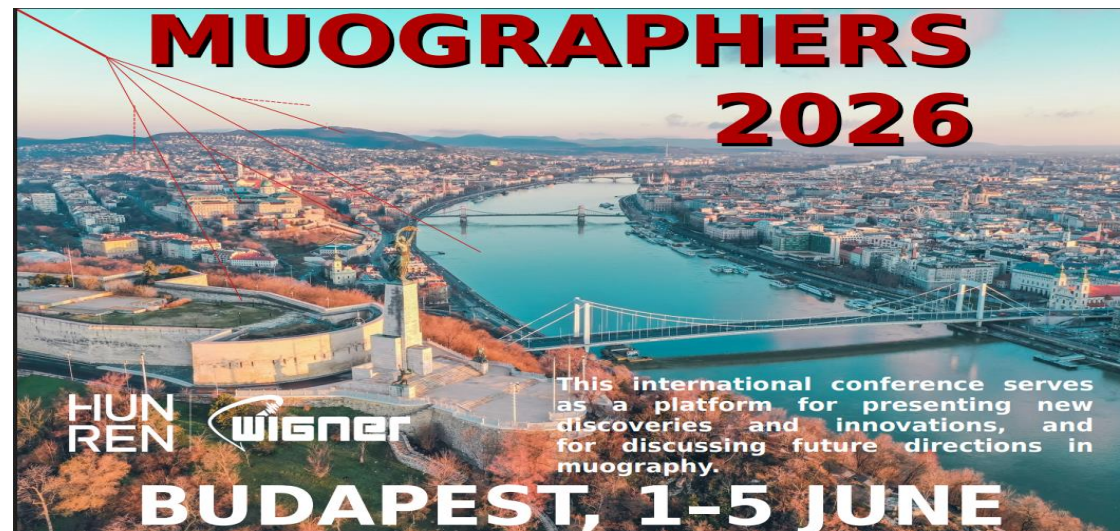

Talk outline

1

Motivation

2

RPC Technology, fabrication, and assembly

3

Detector Performance

4

Absorption muography

5

Summary and outlook

Motivation

Portable muon telescopes are mostly deployed for measurements in confined environment

- Restricted space for installing the experimental setup
- Logistical challenges in terms of power supply, cabling, etc.
- Example applications: archaeology, mining surveys, and underground geophysical studies

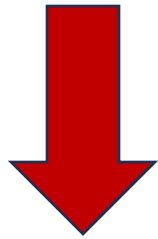

- Portable muon detection systems are increasingly in demand for muography applications in environments requiring flexible installation and transportability

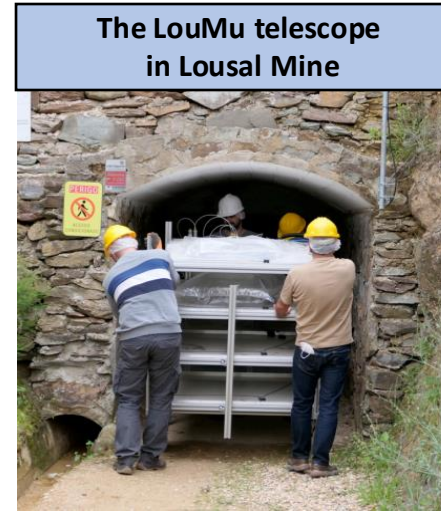

The LouMu telescope in Lousal Mine

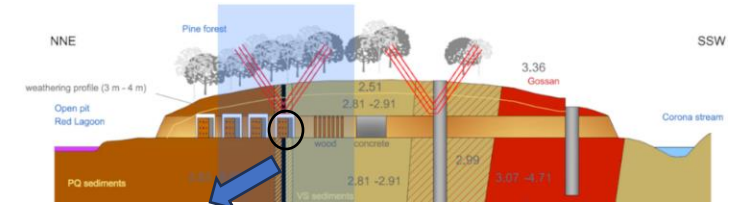

S. Andringa et al., "Testing Muography for Subsurface Geophysical Surveys at the Lousal Mine," *J. Adv. Instrum. Sci.*, vol. 2024, no. 1, Feb. 2024, doi: 10.31526/jais.2024.484.

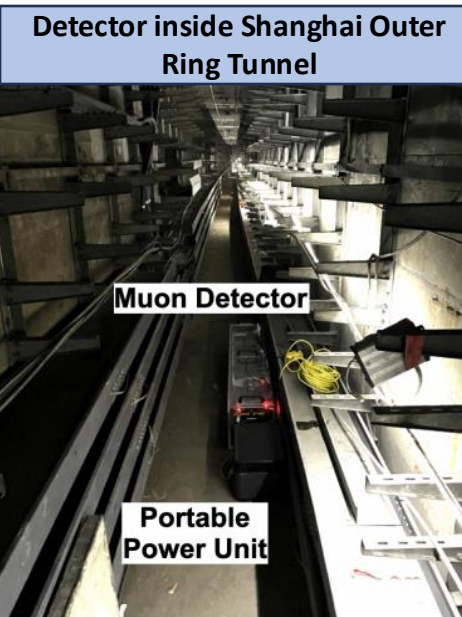

K. S. Khaw et al., "Towards non-invasive sediment monitoring using muography: A pilot run at the Shanghai Outer Ring Tunnel," *J. Appl. Phys.*, vol. 138, p. 114902, 2025.



L. Balázs, G. Nyitrai et al., "3-D muographic inversion in the exploration of cavities and low-density fractured zones," *Geophysical Journal International*, vol. 236, no. 1, pp. 700–710, Jan. 2024, doi: 10.1093/gji/ggad428.

Resistive Plate Chamber

Among the various detector technologies used in muography, Resistive Plate Chambers (RPCs) are widely used for muon detection in both large- and small- scale experiments, due to:

- Low manufacturing cost (suitable for large surface area)
- Simple assembly procedure
- Scalable, from small to large area (>10 m²)
- Good spatial resolution (potentially down to 0.1 mrad)
- Good intrinsic time resolution (from 3 ns to 25 ps, depending on the technical layout)

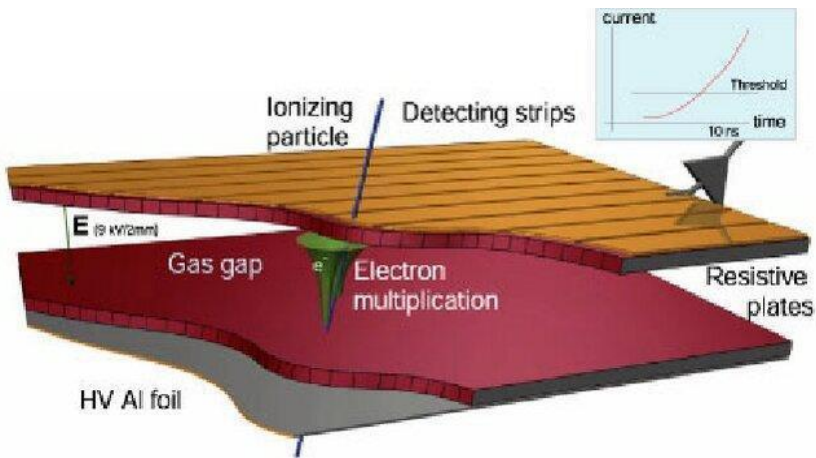

Avalanche creation in a single gap RPC

- glass-based RPC placed inside a gas enclosure containing Gas mixture: $C_2H_2F_4/iC_4H_{10}/SF_6 = 95.2/4.5/0.3$
- High density of freon($C_2H_2F_4$) ensuring high detection efficiency
- Good quenching properties(iC_4H_{10}) and electronegativity(SF_6) → good rate capability and slow detector aging

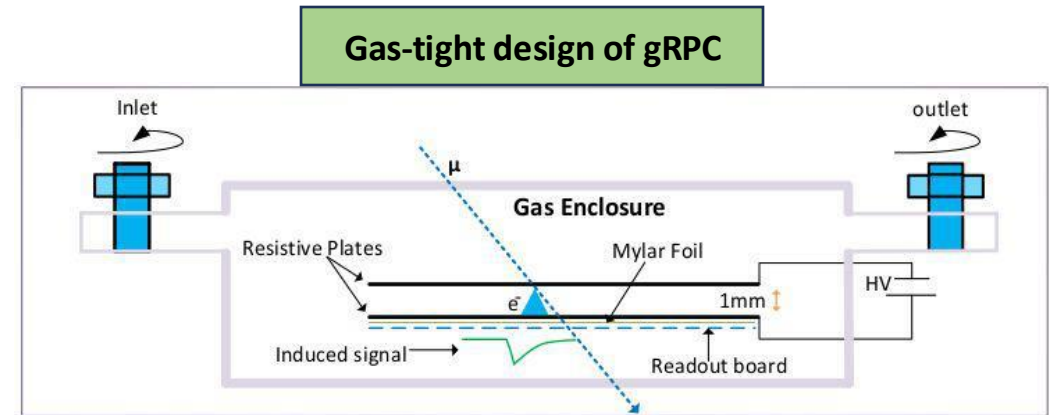

S. Ikram *et al.*, "Development and performance analysis of glass-based gas-tight RPCs for muography applications," *J. Appl. Phys.*, vol. 138, no. 17, p. 174502, Nov. 2025, doi: 10.1063/5.0275200.

- No continuous gas flow during operation
- More portable, autonomous, and safer, making it suitable for confined or remote field locations (no gas bottles on-site)
- Simpler, lower-maintenance operation with reduced gas consumption

RPC prototype

As part of the project, three glass-based RPC prototypes with slightly different characteristics are developed within collaboration

Detector	A	B	C
Box type	Aluminium box	Acrylic box	Closed with top and bottom PCBs
Electrode thickness	1.1 mm	3 mm	1.1 mm
Electrode active area	16 × 16 cm ²	16 × 16 cm ²	28 × 28 cm ²
Gas gap	1 mm, Single gap	2 mm, Single gap	1 mm, Double gap
Gas mixture		C ₂ H ₂ F ₄ /C ₄ H ₁₀ /SF ₆ = 95.2/4.5/0.3	
Resistive coating	Serigraphy	Spray gun	Spray gun
Readout strips/strip pitch	16 - 1D/1 cm	16 × 16 - 2D/1 cm	32 × 32 - 2D/0.8 cm
DAQ		NIM + CEAN integrated / custom made	
Portability	Yes	Yes (Currently operating in gas flow mode)	Yes (Currently operating in gas flow mode)
Collaboration	UCLouvain	NISER	VUB

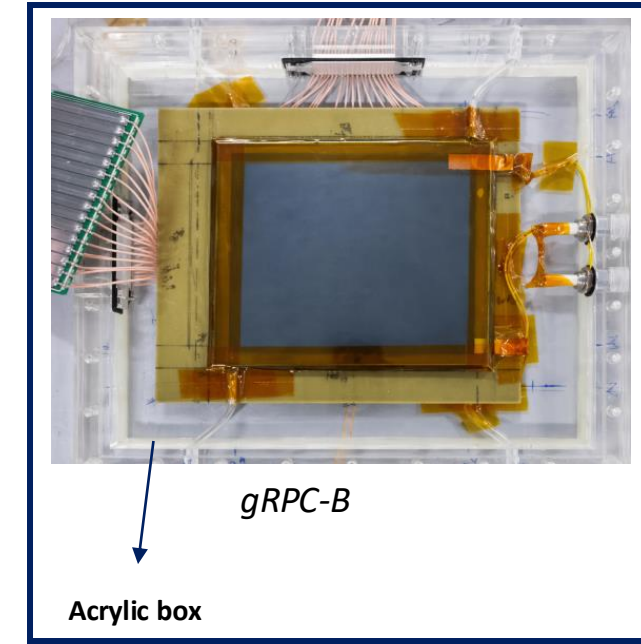
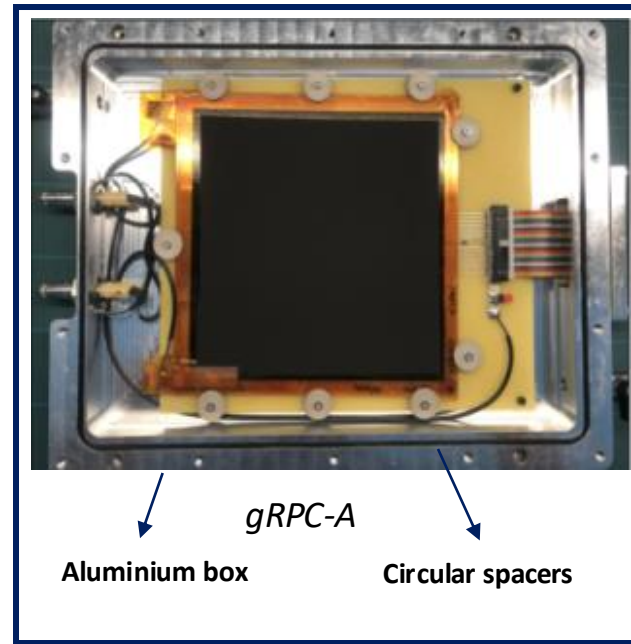

Inside view of detectors

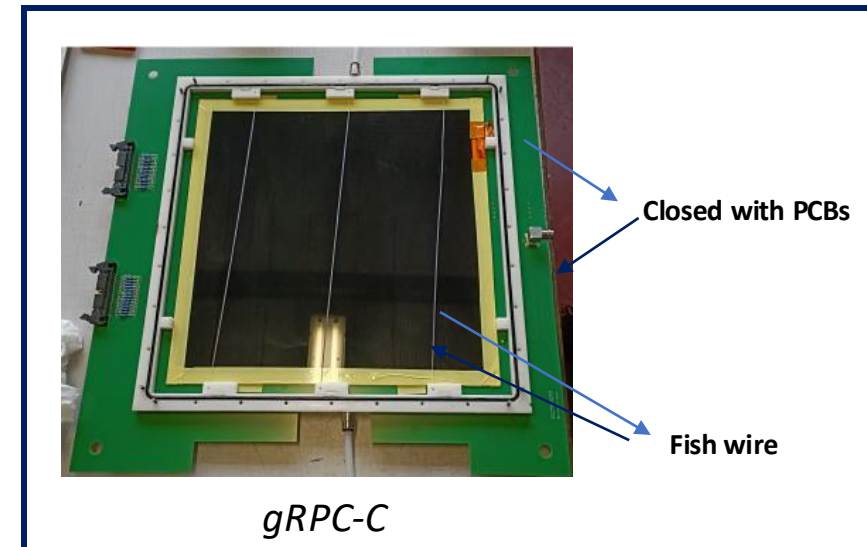

RPC prototype (Components)

Coating methods

- Serigraphy & hand spraying
- Uniformity of surface resistivity
- The resistivity values shown to be stable

Hand sprayed coating

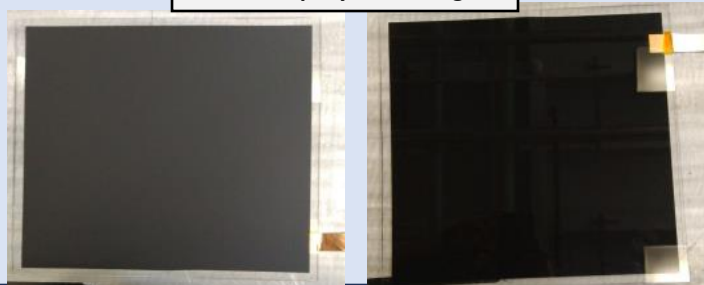

Serigraphy

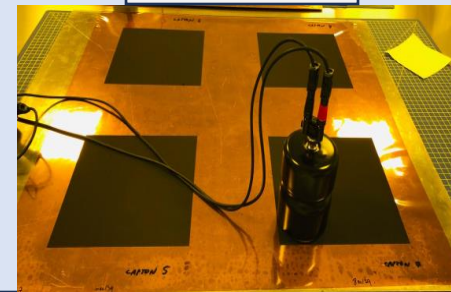

PCB design

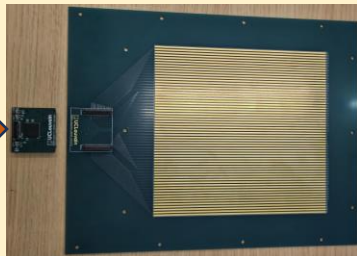
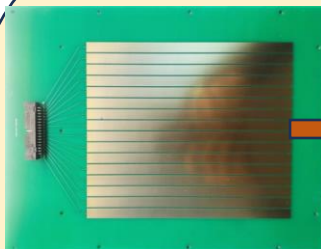

gRPC- A:

- Incorporates 16 copper strips (1cm width) embedded in the PCB
- Copper traces are integrated to route signals to the readout electronics
- Currently under development to upgrade from 16 to 64 strips for higher granularity

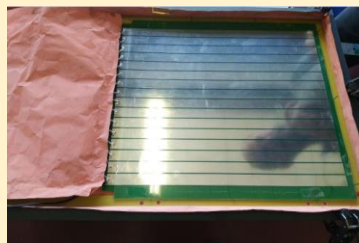

gRPC-B:

- 16 copper strips (strip pitch 1 cm) integrated
- Cables soldered on the strips to guide signals to the readout

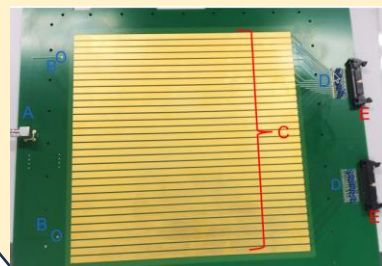

gRPC- C:

- BNC connector for HV connection
- 32 readout strips integrated on the PCB
- Resistors for 50 Ω termination
- Flat cable connectors for signal collection

3D printed frames

- O-ring channels provide gas tightness
- Gas distribution slots built into the frame ensure uniform gas flow
- Restricting the gas volume and make the detector leak tight

- Currently incorporated in gRPC-C
- Such a frame is under development for prototype A

equipped in gRPC-C



CAD model

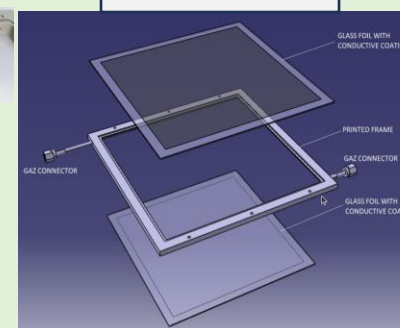

Under development



Stability and Performance studies

Prototype A

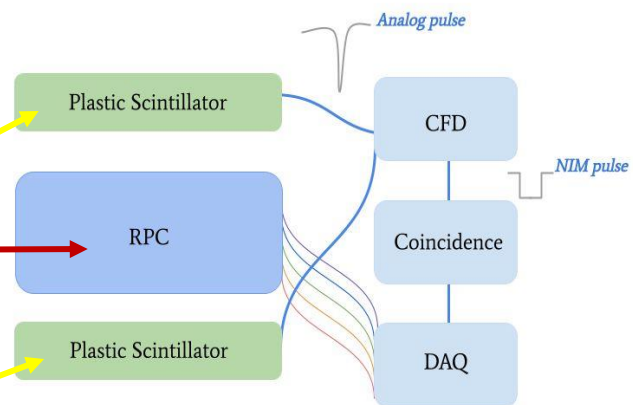
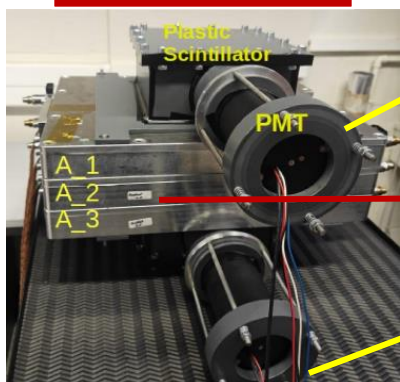

- Plastic scintillators provide the detector's trigger signal
- All 16 readout strips are read out simultaneously as a pre-trigger
- The DAQ uses a CMS RPC Front End Board and an FPGA for data acquisition
- Prototype A performance evaluated by correlating RPC and scintillator muon events

$$\epsilon = \frac{N(\text{RPC hit after filters} \wedge \text{scintillator hit after coincidence})}{N(\text{scintillator hit after coincidence})} \times 100$$

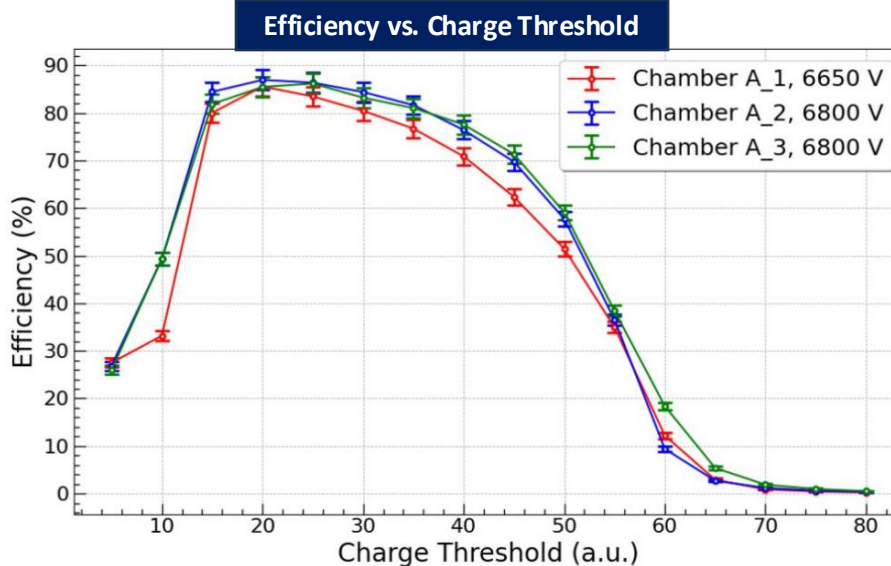

- 3 identical chambers (A₁–A₃); HV: 6.65 vs 6.8 kV
- Higher efficiency at 6.8 kV (optimal working point)
- Maximum efficiency ~85% at threshold 30 a.u.
- Efficiency decreases at higher thresholds

Surface resistivity monitoring

- Resistive coating stability is critical for uniform voltage distribution
- Resistivity of three glass plates monitored over 4 months alongside temperature and humidity to separate environmental effects from coating degradation
- Resistivity stable within ~350–600 kΩ/□ — fluctuations driven by environment
- Consistent results confirm the reliability of serigraphy coating and long-term RPC robustness

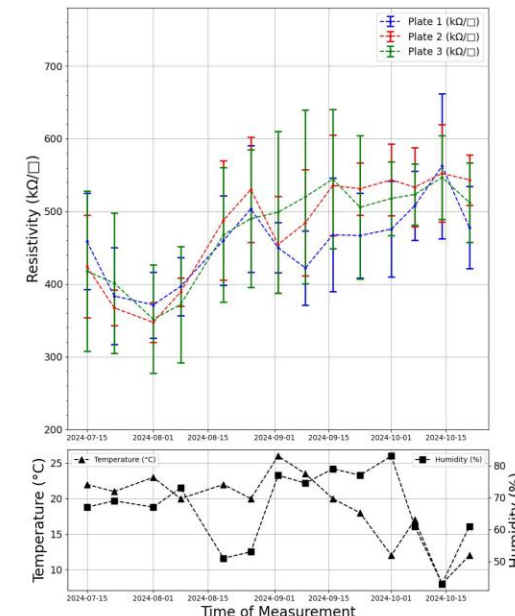

Efficiency vs. No of Days

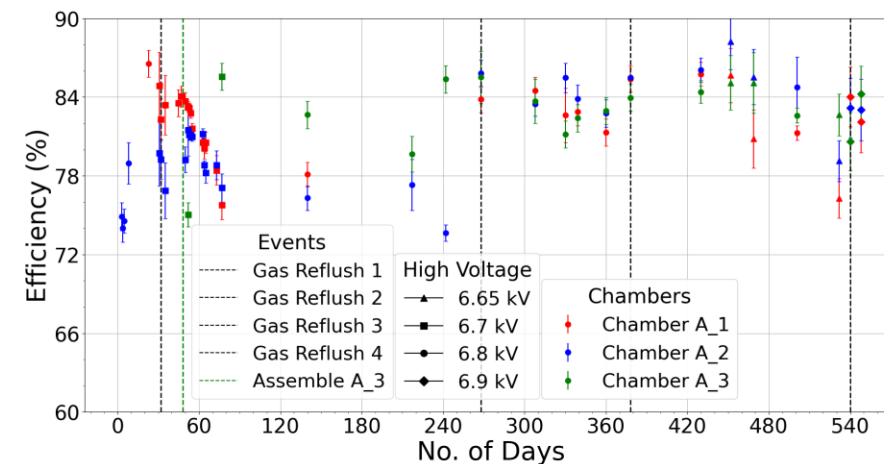

- Long term stability tracked over a year for the same chambers.
- Periodic gas flushed restore efficiency after gradual decline
- Stable good performance maintained for over a year

Stability and Performance studies

Prototype B

Layout of RPC module

Y - Readout

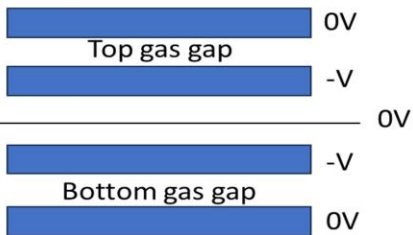

X - Readout



- ❑ CAEN DT5550W complete DAQ system is used.
- ❑ Based on PETIROC 2A + FPGA.
- ❑ Charge dynamic range 160 fC to 400 pC.

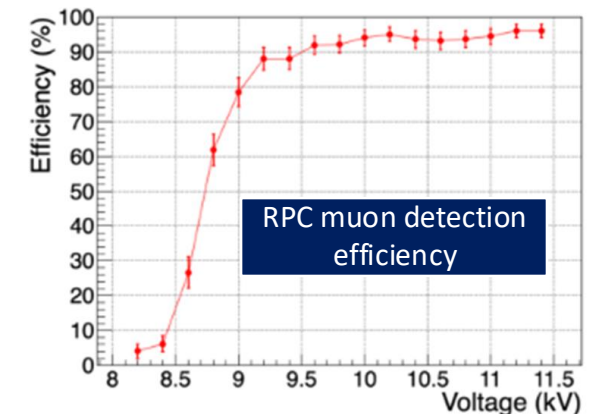
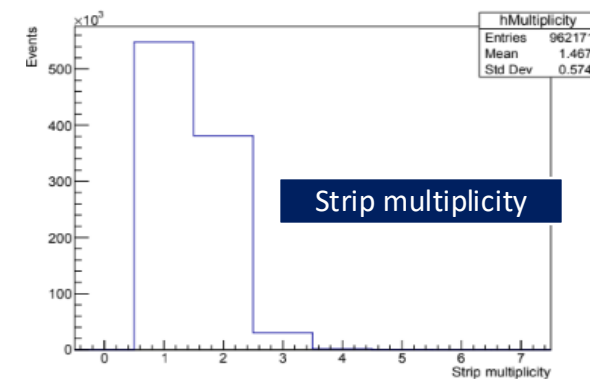

- Most of muon events are confined to one or two strips.
- The measured RPC cosmic-ray muon detection efficiency is $\geq 95\%$ from 10 kV applied voltage onwards.

Air tightness of Acrylic casing

- Relative humidity inside the acrylic casing is monitored using DHT22 sensors.
- An Arduino UNO R3 board is used to record the RH data.
- One month of measurements show that the internal RH remains stable, despite fluctuations in atmospheric humidity.

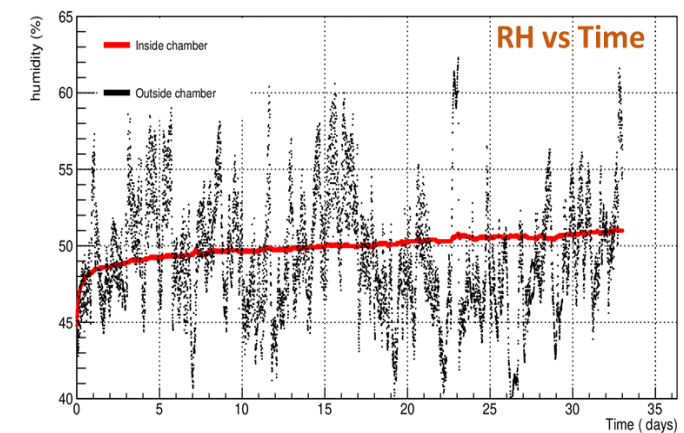
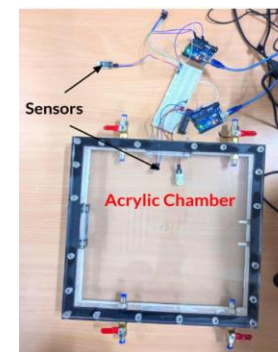

Stability and Performance studies

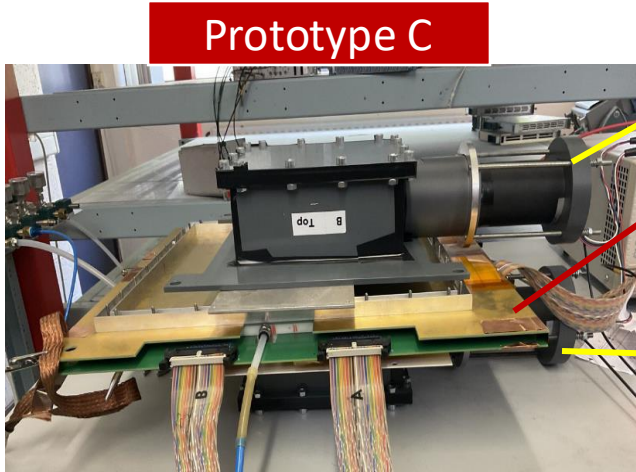

Prototype C

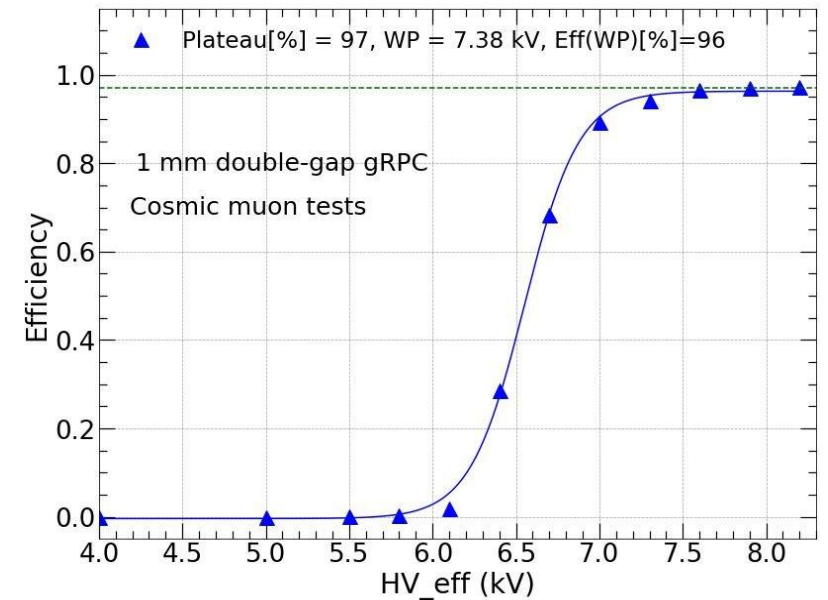
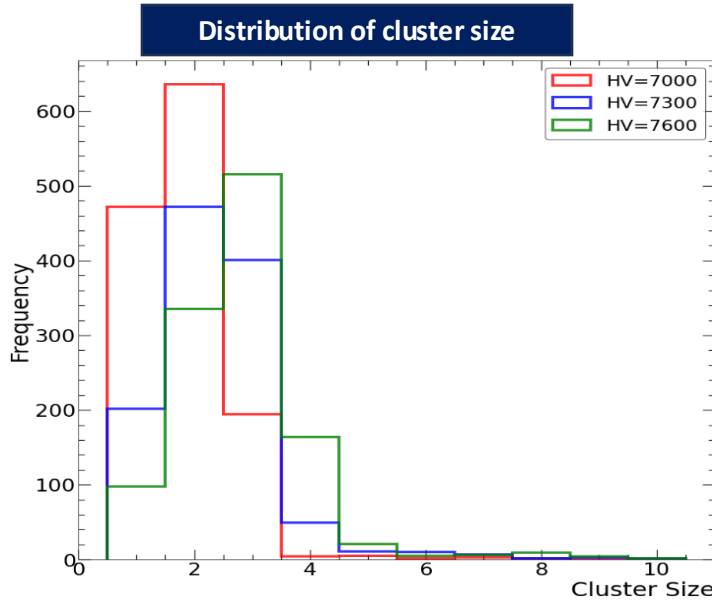
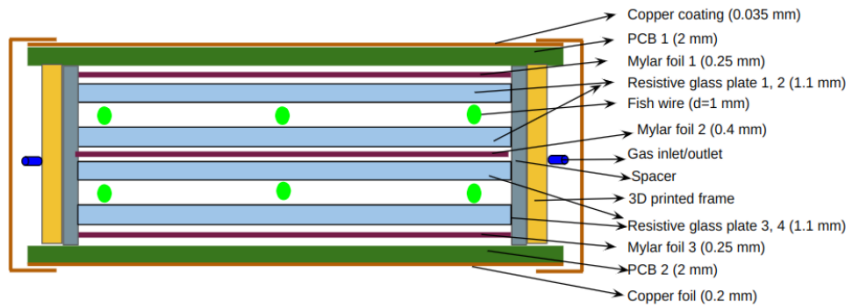
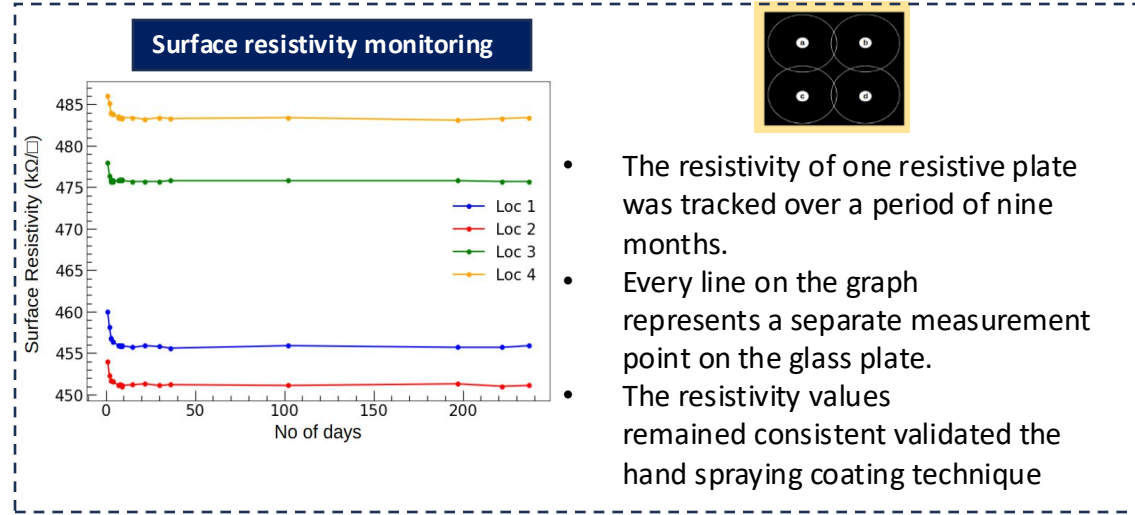
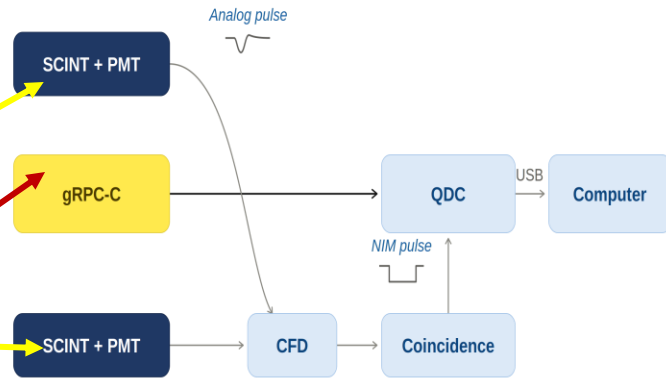

- The experimental setup for data collection with the double-gap gRPC, positioned between two trigger scintillators.
- The trigger scintillators used for the performance studies were the 16 cm x 16 cm scintillators
- Due to the reduced active area of the scintillators, only 18 strips of the detector out of 32 were covered.

- Data collected at three distinct voltage values (7000 V, 7300 V and 7600 V) with 10000 triggers.
- Marginal rise in cluster size with increased applied voltage,
- The majority of events exhibit a cluster size ranging from 0 to 4.

- The efficiency starts to increase after 6 kV, reaching a plateau at ~97% roughly at the HV value of 7.5 kV.
- The estimated WP for the double-gap gRPC is 7.38 kV, and the efficiency at the WP is 96%.

Absorption muography

Muon telescope

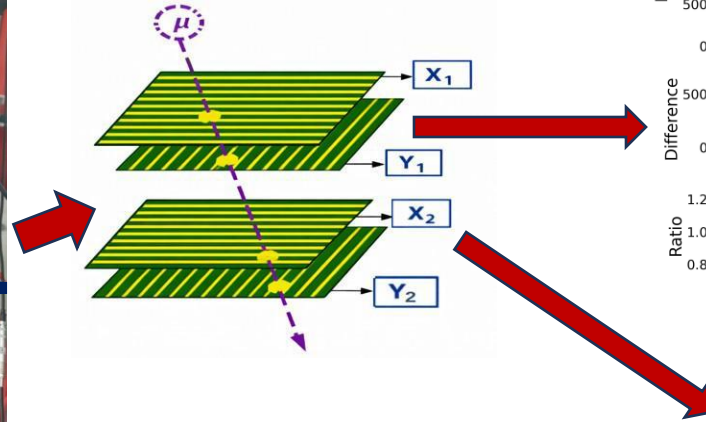
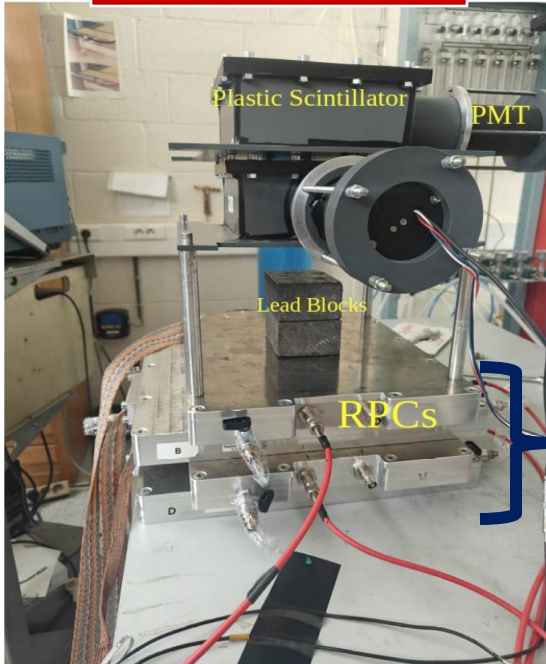

- a controlled muon absorption study in the laboratory using prototype A
- Experimental setup for muon absorption tomography
- Using two plastic scintillators positioned 15 cm above the RPC chambers supported by four cylindrical aluminum pillars
- Two layers of four RPCs are placed below — Layer 0 and Layer 1
- They provide two-dimensional X–Y information
- As absorbers, two lead blocks, each measuring $10 \times 7.5 \times 4.5 \text{ cm}^3$
- These blocks were placed between the scintillators and RPCs in a stacked configuration.

Layer 0

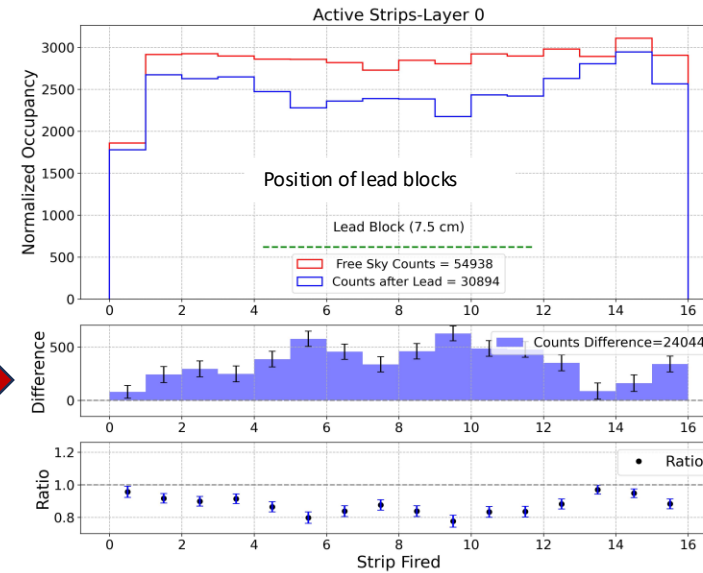

Layer 1

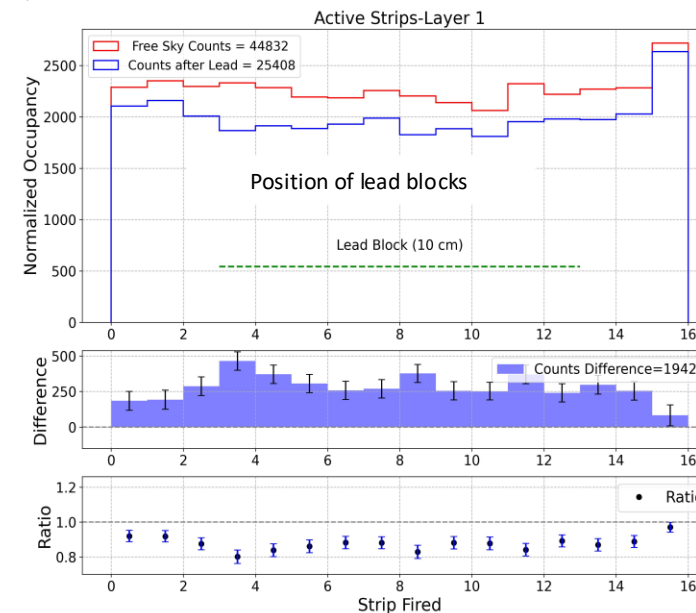

- The occupancy plots present the normalized muon counts as a function of strip fired for each detector layer, under both free sky and lead block(s).
- The key observation is a clear reduction in muon counts at the position of the lead blocks and their immediate surroundings
- The difference and ratio plots further quantify the attenuation, highlighting the strips most affected by the absorber and the extent of the shielding effect.
- confirming that the gas-tight RPCs can detect a dense object through muon absorption.

Summary and outlook

- Three gRPC prototypes (single-gap and double-gap) with slightly different layouts have been built and characterized to gain construction experience and compare performances.
- The design prioritizes modular construction, mechanical robustness, operational safety, autonomous (gas-tight) functionality, and cost-effectiveness, coupled to a scalable multi-channel DAQ.
- Measurements with atmospheric muons using lead blocks demonstrated reliable tracking capability, confirming the suitability of this architecture for muographic measurements.

Upcoming milestones

- Construction of the muon telescope is in progress, with additional double-gap RPC modules to be developed and the existing tracking setup further assessed.
- Performance studies with eco-friendly (alternative) gas mixtures will be carried out to eliminate high-GWP gases.
- MAROC chip for the readout to increase detector granularity

S. Ikram et al., "Development and Performance Analysis of Glass-Based Gas-Tight RPCs for Muography Applications," J. Appl. Phys., vol. 138, Art. no. 174502, 2025.

V. Kumar et al., "Performance Testing of Gas-Tight Portable RPC for Muography Applications," J. Instrum., vol. 19, C04027, 2024.

Abhishek et al., "A modular muon telescope for tomography and radiography applications," Nucl. Instrum. Methods Phys. Res. A, vol. 1075, p. 170399, 2025, doi: 10.1016/j.nima.2025.170399.

A. Samalan et al., "Small-area portable resistive plate chambers for muography," arXiv, Nov. 2023. [Online]. Available: <https://arxiv.org/abs/2311.11451>



Thank you

Back up slides

Detector technologies for muography applications

Type	Surface	Resolution	Construction	Readout	Cost
<i>Plastic scintillators</i>					
Square bars	1-4 m ²	>10 mrad	Simple	Simple	Low
Triangular bars	1-2 m ²	<10 mrad	Simple	Medium	Medium
Scintillating fibers	1-2 m ²	0.1 mrad	Medium	Complex	High
<i>Gaseous detectors</i>					
Proportional tubes	1-4 m ²	10 mrad	Simple	Simple	Low
Multi-wire chambers	>4 m ²	<1 mrad	Medium	Simple	Medium
Drift chambers	>4 m ²	0.1 mrad	Complex	Complex	High
Resistive plate chambers	>10 m ²	0.1 mrad	Simple	Medium	Low
<i>Nuclear emulsion detectors</i>	>4 m ²	0.1 mrad	Simple	Complex	Low

Custom made DAQ

Prototype A

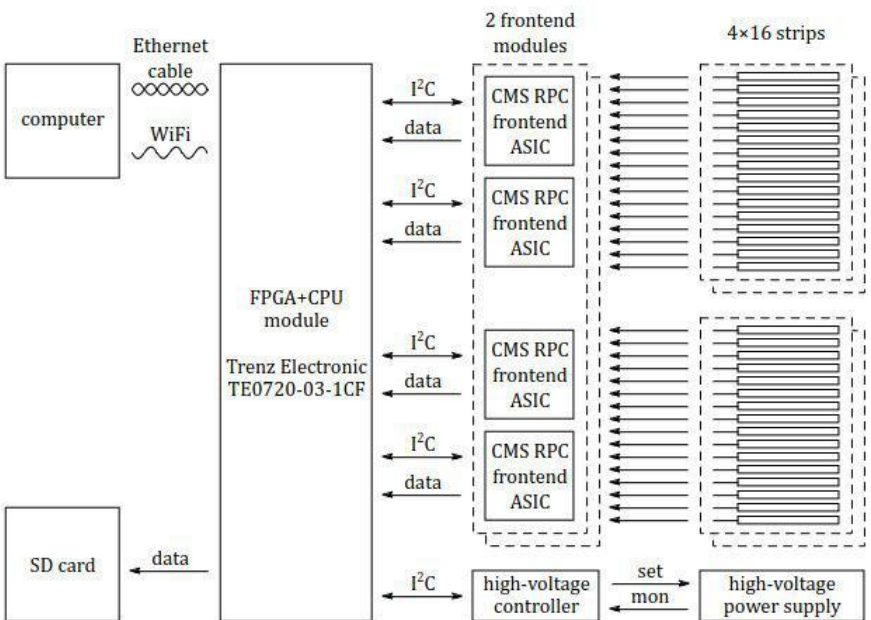

Technical layout of the custom made DAQ

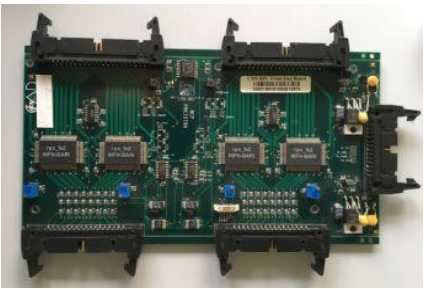
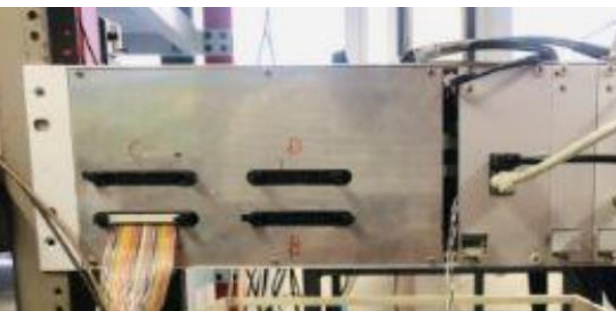

4 × 16 channel CMS electronics used for the DAQ

Prototype B

- ASIC (PETIROC) and FPGA based DAQ system is being tested to study the RPC signals
- Single channel portable power supply module will be used to power all RPCs



PETIROC ASIC:

- Input channels: 32 inputs
(Four ASICs have 128 inputs)
- Signal polarity: positive or negative
- Dynamic range: 160 fC up to 480 pC
- 32 trigger outputs
- 40 ps bin TDC

DT5550W DAQ System



CAEN A7512DN

CAEN A7512DN single channel power supply module:

- Single output channel
- The maximum output voltage = 12 kV
- 200 mV monitor resolution
- The maximum current = 20 μA
- 500 pA monitor resolution

Stability and performance studies (prototype C)

Results of the performance studies of the double gap chamber gRPC-C1 obtained from the data collected using the CAEN QDC:

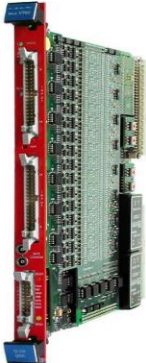
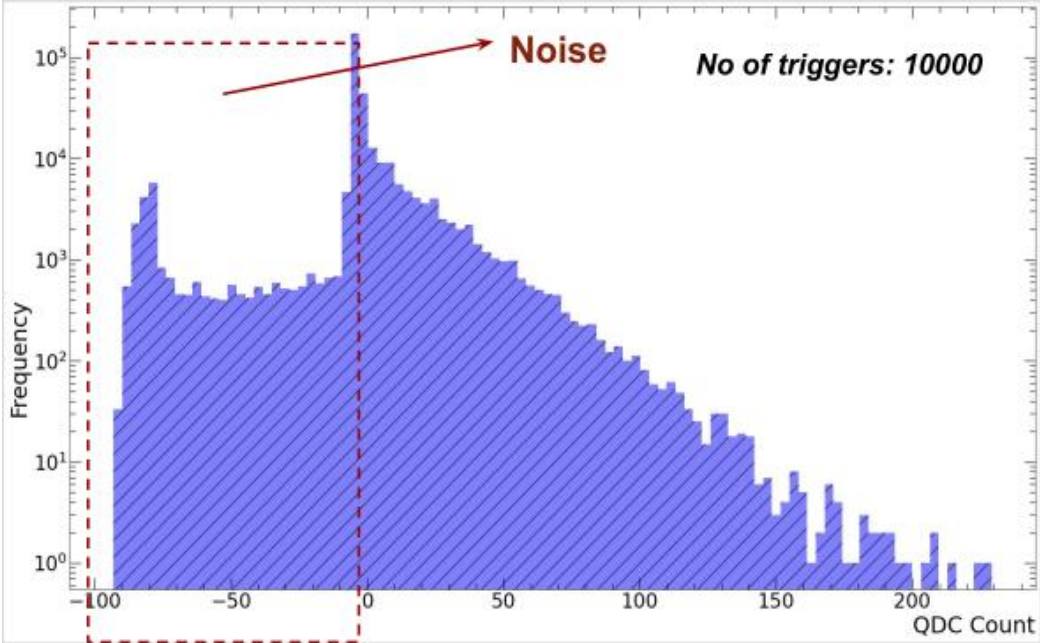

CAEN 32 channel QDC

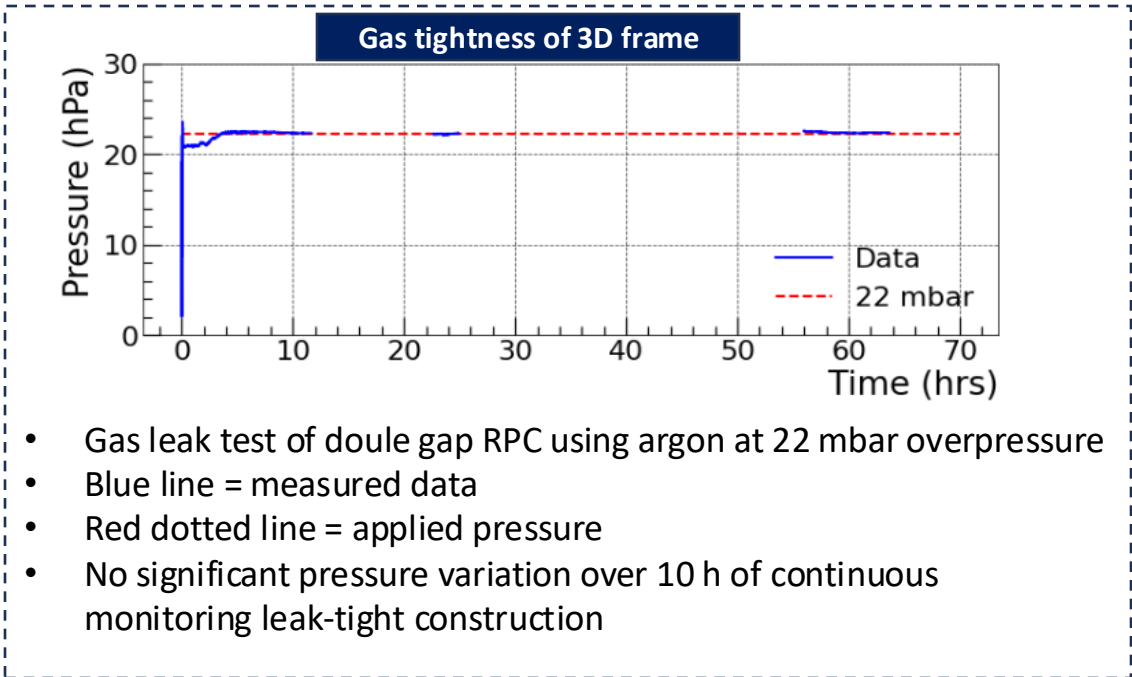

- Gas leak test of double gap RPC using argon at 22 mbar overpressure
- Blue line = measured data
- Red dotted line = applied pressure
- No significant pressure variation over 10 h of continuous monitoring leak-tight construction

- For event selection, a threshold (QDC_{thr}) is applied to the data collected from each QDC channel
- QDC_{thr} is estimated from the Pedestal data collected :
- $QDC_{thr}(Channel_i) = \mu_i + 3 \sigma_i ;$

Where $\mu_i = \text{Mean}(QDC_{pedestal_i})$,

$$\sigma_i = \sqrt{\frac{\sum(QDC_{pedestal_i} - \mu_i)^2}{\text{No of } QDC_{pedestal_i}}}$$

- A strip_i is considered as part of the event only if: $QDC_{val_i} > QDC_{thr_i}$
- Cuts applied for event selection and efficiency measurement: 1) QDC count > channel threshold, 2) Cluster multiplicity < 3, 3) Cluster size < 4

Stability and performance studies (prototype C)

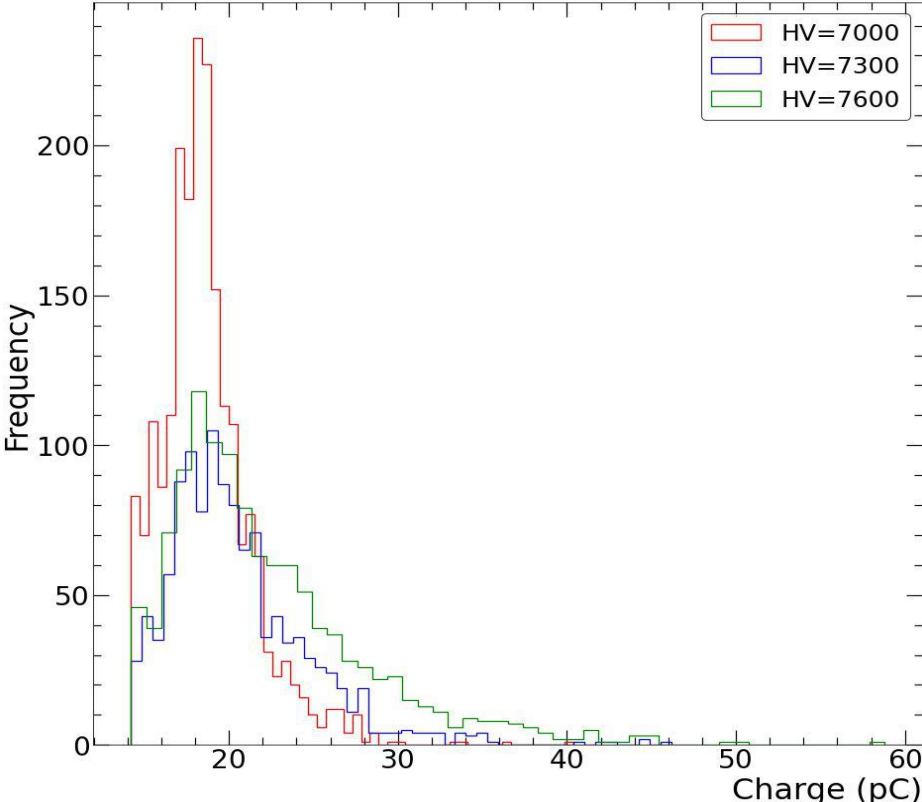

pulse charge increases as the HV increases

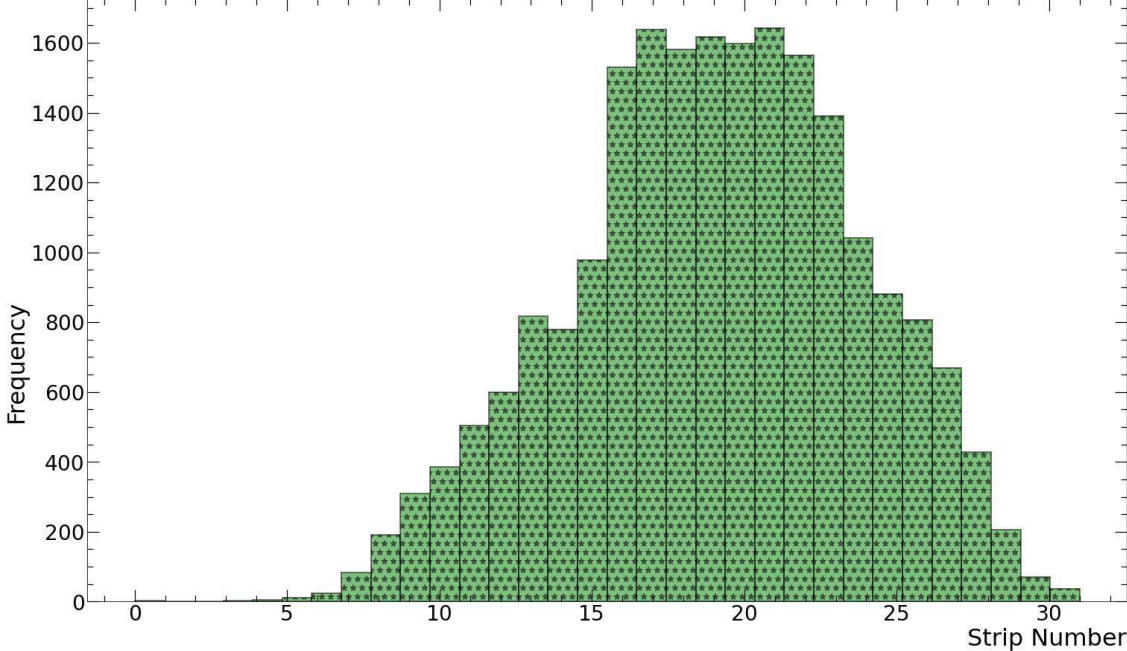

Occupancy distribution at working point HV=7000 V

- The observed shift to the right is attributed to the off-center placement of trigger scintillators.
- The small size of the scintillators (16x16 cm) in comparison to the RPC active area (28x28 cm) results in a reduction in statistics across approximately 16 strips

Filters for offline noise reduction

- Three noise suppression filters applied during analysis (gRPC-A):

- 1) Time filter (15 ns time window),
- 2) Strip multiplicity ≤ 2
- 3) Cluster size = 1

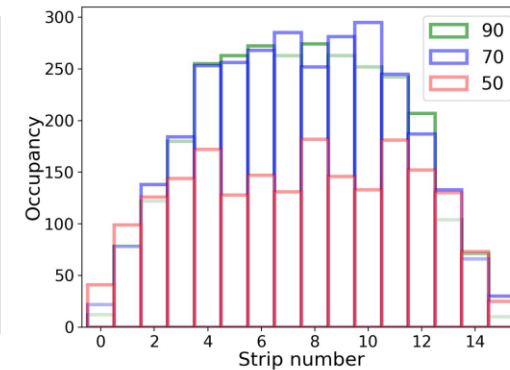
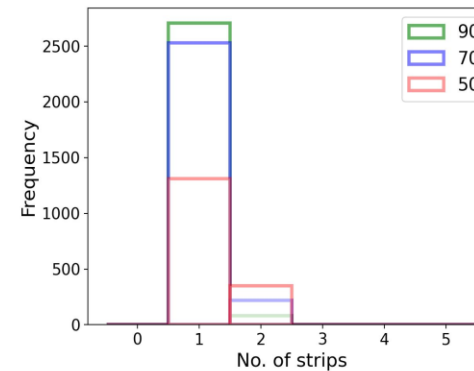
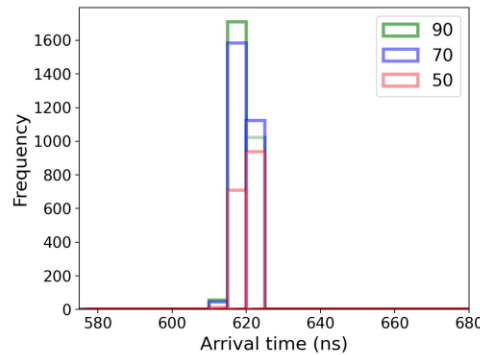
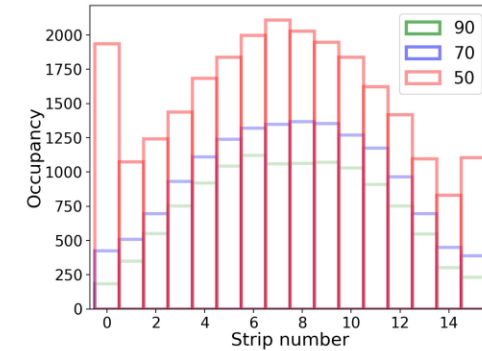
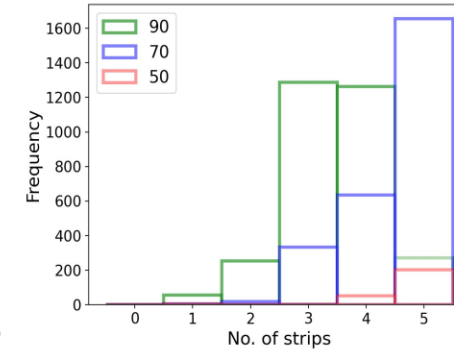
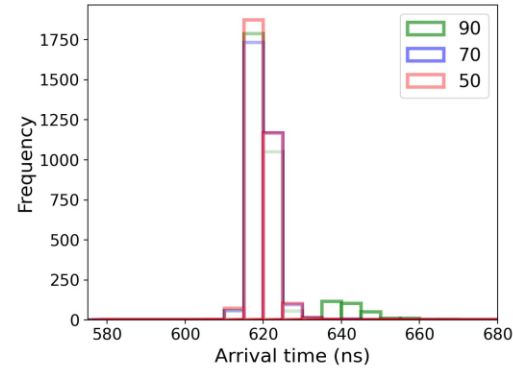

Threshold	50	70	90
No. of events in PMTs	3479	3298	3483
No filter	93.4 ± 0.4 %	93.5 ± 0.4 %	93.7 ± 0.4 %
Time filter (610-625 ns)	89.7 ± 0.5 %	89.7 ± 0.5 %	83.2 ± 0.6 %
No. of strips ≤ 2	63.8 ± 0.8 %	87.5 ± 0.6 %	82.3 ± 0.6 %
No. of clusters = 1	47.7 ± 0.8 %	83.4 ± 0.6 %	80.0 ± 0.7 %

$C_2H_2F_4/R134a$

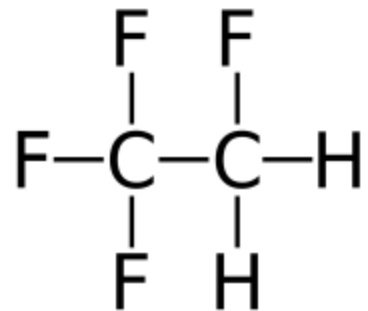

GWP 1430



HFO-1234ze/ $C_3H_2F_4$

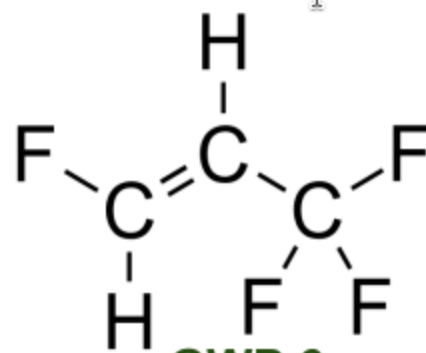

GWP 6



CO_2

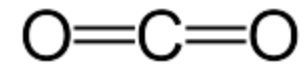

GWP 1